

ELECTRONIC METAL LOCATORS

Basic Types and Design Factors

Here is a rundown on what's available for the non-military user. Comparative characteristics and performance of the beat-frequency, induction-balance, and transmitter-receiver types.

By DONALD E. LANCASTER

The advancing electronic art has made possible a new family of underground metal locators. These light weight, sensitive instruments are designed as non-industrial "sport" types, aimed mainly at the mineral prospector, the beachcomber, and the treasure hunter. Today the outdoor adventurer has a choice of fifty different instruments available from a dozen firms, varying in price from a few dollars up to specialized thousand-dollar underwater models with many versions doubling as effective pipe and buried wire locators. Industrial models operate on the same basic principles.

Although there are several basic detector types, they all share several common design principles. Obvious goals of a locator are a high sensitivity to very small objects, deep penetration, and the sharp discrimination of the object outline. No basic detector type can possibly meet all three goals, since each must emphasize one particular factor.

Basic Operating Principles

All electronic locators have a transmitter used to illuminate a desired area and a second circuit to interpret any changes in that illumination caused by presence of metal. Loop antennas often used to couple the signals to from the earth due to their small and exactly predictable field patterns.

There are several effects a metal target will have if brought near a loop antenna. First, the inductance of the loop will change. If the metal is iron, the inductance will increase, just as an iron core increases the inductance of an air-core coil. If

the metal is non-magnetic, it will decrease the inductance, just as brass core is often used to decrease the inductance of an r.f. tuning coil. Secondly, the metal will distort the normally predictable field pattern of the antenna. This distortion may then be sensed by electronic means.

Finally, the metal will receive the transmitted signal and rebroadcast or reflect it from its own location, just as a radar illuminates a target which in turn rebroadcasts or reflects energy to a receiver.

The mathematics behind loop-antenna operation reveals two energy terms, an inductive coupling term and a resistive coupling term. Both terms are of equal importance one-sixth of a wavelength away from the loop, but for closer distances the inductive term is much stronger. This is the case with practically all electronic locators, and the design of a locator may then use such inductive concepts as mutual inductance and loosely coupled transformers for mathematical analysis.

The basic laws behind inductive coupling dramatically illustrate why metal location over any appreciable distance is a major design problem, and painfully show why the performance of simple experimental locator circuits is often highly disappointing. It turns out that the received signal produced by an inductively coupled target will normally be proportional to the cube of the target diameter and inversely proportional to the sixth power of the target depth, neglecting the effects of terrestrial attenuation. A one-inch diameter target will produce only 1/64th the signal of a similar four-inch-diameter target at the same depth; a tar-

	Beat-Frequency	Induction-Balance	Transmitter-Receiver	Underwater
AZLE DISTRIBUTING CO., 141 Lynn Drive, Azle, Texas	X			
DETECTRON CO., Box 234, San Gabriel, Calif.	X	X		
D-TEX ELECTRONICS, Box 246, Garland, Texas	X			
FISCHER RESEARCH LABS., 1961 University Ave., Palo Alto, Calif.	X	X	X	
GARDINER ELECTRONICS, 4729 N. 7th Ave., Phoenix, Ariz.	X		X	X
GEOFINDER CORPORATION, Box 37, Lakewood, Calif.	X		X	
GOLDAK CO., 1542 Glen Oaks Blvd., Glendale, Calif.	X	X	X	X
IGWT ASSOCIATES, Williamsburg, N. M.		X		
METROTECH, INC., 670 National Ave., Mountain View, Calif.	X		X	
RACOM EQUIPMENT CO., Box 13469, Orlando, Fla.	X			
RAYSCOPE CO., Box 1715, North Hollywood, Calif.	X	X	X	
RELCO INDUSTRIES, Box 10563, Houston 18, Texas	X			
SHARPE INSTRUMENTS INC., 967 Maryvale Drive, Buffalo, N. Y.			X	
STATES ELECTRONICS CORP., 96 Gold St., New York, N. Y.				X
UNDERGROUND EXPLORATIONS, Box 793, Menlo Park, Calif.	X	X	X	
WHITES ELECTRONICS, 1011 Pleasant Valley, Sweethome, Oreg.	X	X		

Table 1. Manufacturers of metal locators for sport use, with types available from each firm indicated.

get four feet deep will only produce 1/4096th the response of an identical one-foot-deep target.

It is possible to obtain deep penetration by careful control of the loop-antenna field patterns, but a drastic reduction in small-object detectability must inevitably accompany such a design.

Operating Frequencies

The round-trip inductive coupling between a target and an antenna in air increases as the square of the operating frequency, while the terrestrial absorption becomes worse as the square root of frequency. Changing from an operating frequency of 10kHz to one of 1MHz will increase the received signal by a factor of 10,000, but the terrestrial absorption will simultaneously become ten times worse. The highest possible operating frequency that will still allow penetration to the desired depth without excessive attenuation should always be used.

Terrestrial attenuation is highly dependent upon the resistivity of the earth and its moisture content, but as a worse-case rule-of-thumb for normal soils, rock, and sands, attenuation values are around 0.1 decibels per foot at 10kHz, 1.0 decibels per foot at 1MHz, and 10 decibels per foot at 100MHz. These are one-way values. An eight-foot-deep target will have 16 decibels of terrestrial attenuation added to its normal sixth-order drop-

off with depth at 1MHz. Some soils will make the attenuation somewhat less than expected at high frequencies due to a high dielectric constant which acts as "bypass capacitor" to allow the high-frequency energy to traverse a lossy medium more freely.

Ordinary river water actually has less attenuation than most soils, and the problem in freshwater locator operation is primarily one of waterproofing and sealing the circuitry. Such is not the case with sea water, salt lakes, and brackish swamps, for salt water is both highly conductive and moderately corrosive, requiring specialized detector designs that ordinarily make use of very low operating frequencies.

Most commercial non-aquatic instruments operate in the 50 kHz to 2 MHz region, with newer designs favoring the higher frequencies, particularly where high resolution to small objects is an important consideration.

Beat-Frequency Locator

This is the oldest type and often the simplest to manufacture. The beat-frequency metal locator is characterized by low cost, good sensitivity to relatively small objects, and very limited depth penetration. It is favored by beachcombers and coin collectors but is of little or no practical value in the

location of pipes, mineral veins, or other deeply buried objects.

The change in loop inductance in the presence of a buried target is the basic principle of operation. Two similar r.f. oscillators are used, one an adjustable reference oscillator and a second that uses a search loop as part of its frequency-determining tank. The outputs of the two oscillators are mixed together and the difference frequency is amplified and fed to a speaker, headphone, or a meter. The block diagram of the basic beat-frequency detector system is illustrated in Fig. 1.

In operation, the reference oscillator is adjusted to a few hertz lower in frequency than the loop oscillator, producing a deep growl in the speaker. If the search loop nears a magnetic con-

ductor, the loop's inductance goes up which slightly lowers the frequency of the loop oscillator. This in turn lowers the difference between the two oscillators, and the audio tone drops in pitch accordingly. A non-magnetic conductor does just the opposite - it lowers the loop inductance, raises the loop oscillator frequency, and raises the pitch of the difference note. The beat-frequency locator can then discriminate between magnetic and non-magnetic conductors by the decrease or increase in pitch of the audio note produced as a target is detected.

The size of the search loop will determine the depth penetration and the small-object resolution. The larger the loop, the deeper the penetration, and the larger an object has to be to produce detection.

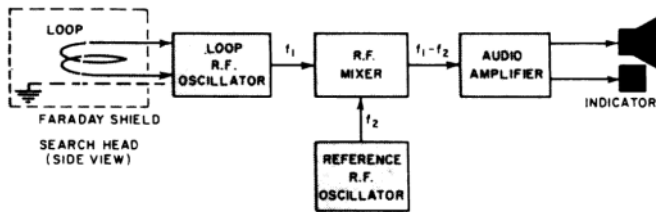

Fig. 1. Block diagram of the beat-frequency metal locator.

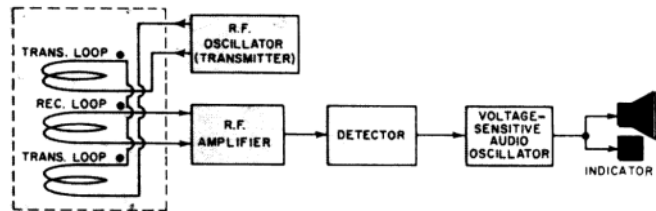

Fig. 2. Induction-balance locator block diagram.

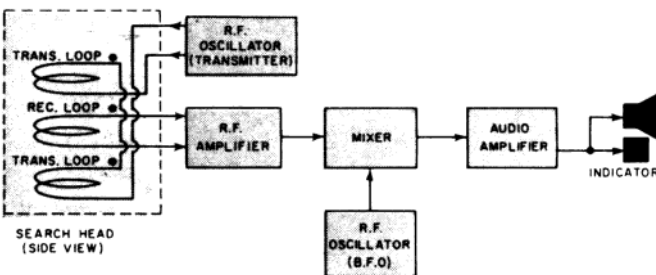

Fig. 3. Alternate audio scheme for the induction-balance locator.

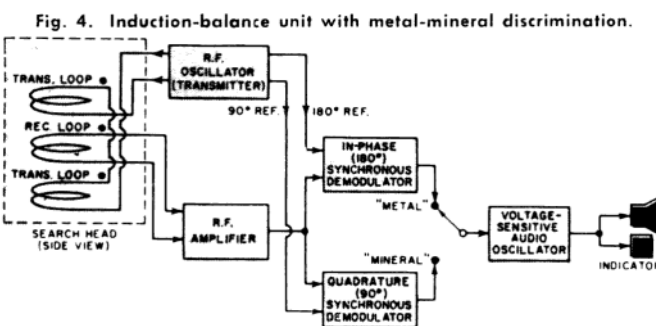

Fig. 4. Induction-balance unit with metal-mineral discrimination.

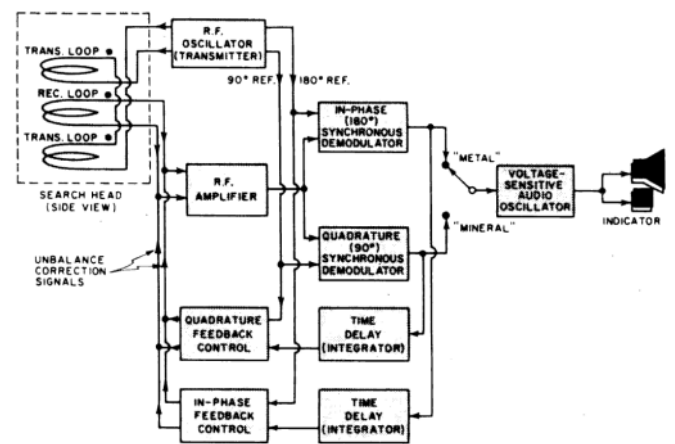

Fig. 5. Automatic drift correction in induction-balance unit.

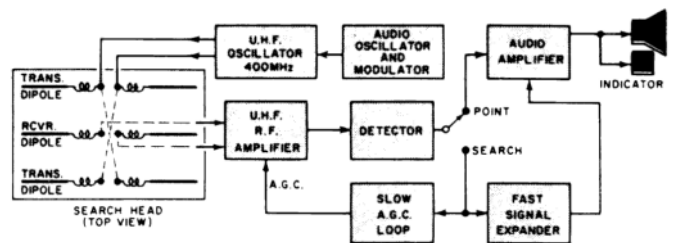

Fig. 6. U.H.F. induction-balance locator operates on metals or non-metals. Search mode eliminates spurious terrain response.

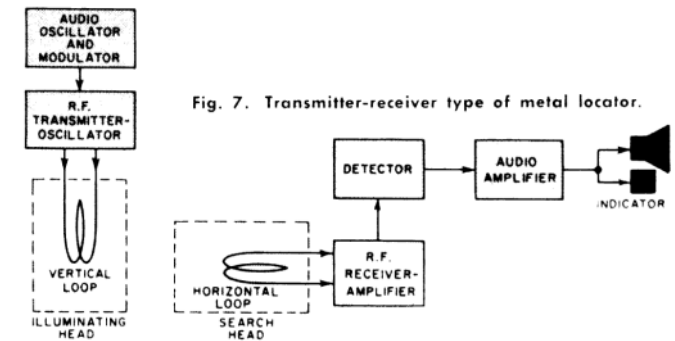

Fig. 7. Transmitter-receiver type of metal locator.

As an example, a target 1/10th the diameter of the search loop at very shallow depths will produce a mutual inductance of roughly 1/1000th the self-inductance of the loop, since the mutual inductance between loop and target varies as the cube of the target diameter. An inductance change of 1 part in 1000 will produce a frequency change of 1 part in 2000. In the case of a 100 kHz locator, this corresponds to a 50Hz shift in audio output. If the search loop were ten inches in diameter, this would correspond to a one-inch diameter target.

Although simple in principle, there are many headaches involved in the design of a quality beat-frequency locator. The oscillators must be very stable, drifting no more than a few hertz per minute; otherwise the instrument must be continuously adjusted. The oscillators cannot be crystal-stabilized, for the tiny inductance changes produced in the search loop would be unable to pull a high-"Q" crystal oscillator even a few hertz.

A second problem is pulling and phase-locking. Two r.f. oscillators at nearly the same frequency will attempt to synchronize each other. This readily occurs if any energy from one oscillator is allowed to reach the other, either by direct radiation or through common supply impedances. Since both oscillators must meet at the mixer, the mixer stage represents a critical design area. High-

impedance, non-pulling inputs are required at this point, along with careful shielding and supply decoupling.

One interesting way to avoid the phase-locking problem entirely is to use a conventional AM radio as a mixer and detector, using the reference frequency of a local AM station as a transfer oscillator. Some commercial models carry this to an extreme; they are simply oscillator attachments that clip onto a transistor radio. Although attractive principle, many compromises are often involved, not the least of which is finding a strong AM station in many areas where such a locator would be used.

Another major problem is that of stray capacitance to ground. Any change in capacitance seen by the loop assembly will also change the loop oscillator's frequency. This could be caused by varying instrument height, the motion of the operator, or foliage effects. One method of minimizing capacitance effects is to use single-turn loops, which result in a very high C to L ratio and a large amount of fixed capacitance shunting the loop. A second method is to use an electrostatic Faraday shield which prevents any external stray capacitance from having any effect upon the loop resonance. A slot must be placed in the shield in order to prevent the shield from acting as a shorted turn

Table 2. Comparative characteristics of the basic types of metal locators discussed in accompanying article.

	BEAT-FREQUENCY LOCATOR	INDUCTION-BALANCE LOCATOR	TRANSMITTER-RECEIVER LOCATOR
1. DEPTH PENETRATION Maximum depth at which a small object produces a strong return	POOR 1 foot	BETTER 2 feet	EXCELLENT 8 feet
2. RESOLUTION Smallest object detectable at four inches depth	GOOD Ring or large coin	EXCELLENT Metal nugget or small coin	POOR 3" sphere
3. WEIGHT Typical weight of commercial models	LIGHTEST 1-5 pounds	HEAVY 3-15 pounds	HEAVIEST 9-25 pounds
4. COST Typical economy commercial unit Typical quality commercial unit	LEAST \$30 \$80	MODERATE*/HIGHEST** \$100* \$150** \$200* \$350**	HIGH \$125 \$225
5. UNIQUE FEATURES	Discriminates between magnetic and non-magnetic conductors	Can discriminate between conductive targets and magnetic soils and ores**	Can triangulate for depth indication
6. COMMON APPLICATIONS	Beachcombing. Locating lost jewelry	Exploring Coin finding	Pipe tracing Prospecting

* Non-synchronous
** Synchronous
Individual instruments will vary widely from performance suggested in this table.

and severely lowering the “Q” of the search-loop assembly that is employed.

Induction-Balance Locator

This is a more sophisticated instrument of better sensitivity and resolution. Depth penetration is better, yet still somewhat limited, and an excellent sensitivity to tiny metallic objects can often be obtained. Fig. 2 shows a typical block diagram. Three loop antennas are used, stacked vertically within the same search-head assembly. The top and bottom loops are connected to an r.f. oscillator; the middle one is connected to a sensitive r.f. amplifier. The two transmitting loops are fed out-of-phase. Under no-target conditions their induced voltages very nearly cancel each other in the receiving loop, resulting in very little net induced receiver voltage. The presence of a target below the bottom loop will upset the balanced induced voltages and produce a signal in the receiving loop. This unbalance signal is then amplified and appears as an output.

The design problems here are entirely different from those of the beat-frequency locator. Mechanical stability of the search head is very important for the loops must be perfectly planar. Temperature and stress can produce breathing of the loops, which can upset the induction balance. No metallic fasteners should be used on the search head, and a minimum of metallic parts of any kind in the vicinity of the search head is highly desirable. A stable transmitter frequency, unaffected by search-head stray capacitance, is mandatory. In the more sophisticated designs, all circuitry must also be phase-stable and drift-free, particularly with respect to temperature or battery voltage.

Since modulating the r.f. source presents balancing problems, c.w. oscillators are normally used whose detected-target output voltage will be d.c. This output may be used to deflect a meter or power an integrated sonic module. Another alternative is to form an audio beat note with a second oscillator and mixer tuned to 1 kHz or so away from the main transmitter. The beat note will have its amplitude proportional to target unbalance and can be amplified to power a loudspeaker or a pair

of headphones. Such an alternate system is shown in Fig.3.

Target Discrimination

Some fancy techniques allow the induction-balance locator to discriminate between conductive metallic targets and magnetic minerals such as black sand or soils with a high iron-ore content. This allows the locator to see through remanent magnetism of the soil, greatly enhancing the sensitivity to marginal targets.

These techniques are accomplished by using the phase information in the received signal. The receiver and transmitter are inductively loose-coupled, so there will be a 90 phase difference between the receiver voltage and the transmitter current. A conductive target will be inductively coupled twice, once from transmitter to target and once from target to receiver, so the receiver unbalance voltage due a target will be phase-shifted twice 90, or 180.

Magnetic sands and remanent magnetism in soils simply increase and distort the inductive coupling without introducing a resistive (180) component. Thus, there will be a 90 phase difference at the receiver between conductive targets on the one hand and magnetic soils on the other hand.

To discriminate between the two, two demodulators (detectors) are used, both of which are synchronized to the transmitted signal. An “in-phase” (180) demodulator will detect only the return from conductive targets, while a “quadrature” (90) demodulator will detect only magnetic minerals. A “Metal-Mineral” selector switch is used to route the desired output to the indicators. Fig. 4 shows diagram of this type of locator.

Automatic Drift Correction

The induction-balance locator can also be made to automatically correct its own unbalance due to loop breathing, ground effects, and varying instrument height. Feedback techniques are used. The output of each phase detector is used to control the introduction of just enough in-phase quadrature transmitter power of proper polarity to exactly buck out the unbalance signal at the input

to the r.f. amplifier. Enough time delay (integration time) is introduced into the feedback path to allow the detection of targets. Otherwise, the target signals would be bucked out with the unbalance and no output would ever reach the indicators. Two to five seconds of delay allows the correction circuitry to keep up with gradual changes in soil conductivity and instrument height yet lets the sudden appearance of a target produce a strong output. One of many possible systems is outlined in Fig. 5.

U.H.F. Type

This metal locator has several unique operating features. Fig. 6 shows the block diagram. The u.h.f. locator is capable of detecting either metallic or non-metallic objects and is able to discriminate between these objects and the normal clutter of rock discontinuities. Operation is somewhat similar to the induction-balance locator, except that the operating frequency is 400 MHz and the loops are replaced by a search array consisting of inductively loaded dipole antennas. Two transmitting dipoles are used with a receiver dipole between them. A figure-eight pattern is produced in the absence of any target resulting in balanced voltages that nearly cancel in the receiver dipole. The presence of any object of uniformly different conductivity and dielectric constant from the surrounding medium upsets the balance and produces an output signal.

There are two modes of operation, the "Search" mode and the "Point" mode. In the "Search" mode, all of the spurious return is averaged out by a long time constant a.g.c. loop, while any sudden changes in the field patterns are greatly amplified by an expander circuit, indicating the edge of a target directly below the search array. In the "point" mode, the receiver output is amplitude-sensitive and the instrument may be used to outline the buried object. The u.h.f. locator is principally used by the military for the detection of metallic and non-metallic mines.

Transmitter-Receiver Instrument

Of the popular locator types the transmitter-receiver instrument is capable of the deepest pene-

tration and is principally used for large-object detection, such as locating buried pipes and tracing mineral veins. Many instruments of this type can also give a relative indication of the depth of target burial by a triangulation method. Utility companies as well as amateurs make extensive use of this particular type of instrument.

If two loop antennas are placed at right angles to each other so that one loop is positioned directly along the null axis of the other, no signal coupling between the two will exist. In practice, one loop is excited with an r.f. oscillator-transmitter. This is usually the vertical rear loop. The other loop forms the front end of a highly sensitive r.f. receiver-amplifier followed by a detector and indicator, as shown in the block diagram of Fig. 7.

In the absence of targets, the received signal is zero because of zero mutual inductance between receiver and transmitter; any energy inductively coupled via a target produces a real signal in proportion to the size and location of the target.

Maximum signal return occurs when the target is almost centered under the receiver loop. For the first few feet of target depth, the distance from transmitter to target changes very little. In addition, more energy is actually delivered to a deeper target than to a very shallow one, due to the field patterns of the transmitting loop. For these two reasons the transmitter-receiver locator retains a very good penetration capability to depths comparable to the instrument length. Only for depths substantially greater than the transmitter and receiver separation does the return begin to fall off as the sixth power of depth.

The price paid for the good penetration is inability to resolve small objects. When a target is in the position of optimum detectability, it is at least four feet away from the transmitter and thus must be physically large to intercept enough transmitter energy to produce a useful receiver voltage. The majority of transmitter-receiver locators are incapable of detecting an object less than three inches in diameter, even if the target is on the surface.

Synchronous demodulation may be employed on the transmitter-receiver locator, but only if

totally balanced circuitry is used. Otherwise the interconnection between receiver and transmitter will itself radiate and distort the normal field patterns.

Design problems include mechanical stability and the minimum use of metal parts in assembly, for either of these factors can eliminate the sharp null obtained at 90 positioning and greatly reduce apparent sensitivity.

Commercial Instruments

Table 1 lists major manufacturers of electronic metal locators intended for sport applications. Table 2 gives the relative performance capabilities of the three sport types in terms of relative cost,

penetration, resolution, weight, and applications. Individual commercial instruments will vary widely from the values shown, depending upon soil conditions, operator experience, the quality of the instrument, and other factors.

In addition to the sport types covered here there are a number of industrial-type metal locators that are used by the utility companies and others. In general, the operation and characteristics of these metal locators are very similar to the sport types covered, although the industrial types may be more expensive and constructed to withstand more physical abuse than a unit that is only used occasionally would encounter.