



BUILD THE **TWO-TONE "WAVERLY" ALARM**

AUDIBLE WARNING OF MANY USES

BY DON LANCASTER

HAVE YOU EVER needed an audio tone source that was really loud, absolutely distinctive, or even downright annoying? If so, the Two-Tone Alarm is for you.

The circuit of the Alarm automatically switches the audible output from 500 to 1000 Hz five times a second, producing a "twee-dell, twee-dell" sound that can't be missed anywhere and positively can't be ignored. By adding an optional potentiometer to the circuit, the sound level can be changed from a high tweet to a low growl.

The Alarm can be set to run continu-

ously or it can be turned on with a local switch or a remotely operated contactor. There are two outputs: a low-level one which can be amplified in any audio amplifier and a high-level one that can be used to drive a conventional speaker directly.

You can use the Alarm as a panic button, a novelty audio device, an electronic doorbell, a selective call, a Science Fair multivibrator demonstrator, a burglar alarm, or as a signalling device for high-noise industrial environments.

Construction. A schematic diagram of the Alarm is shown in Fig. 1. While it is not essential, a printed circuit board greatly simplifies the assembly. If you want to make your own, use the foil pattern and drilling details shown in Fig. 2. Mount the parts as shown in Fig. 3. The integrated circuit polarity is identified by a notch (between pins 1 and 14) and a dot. In the illustrations it is shown

IC
EXPERIMENTER'S
CORNER

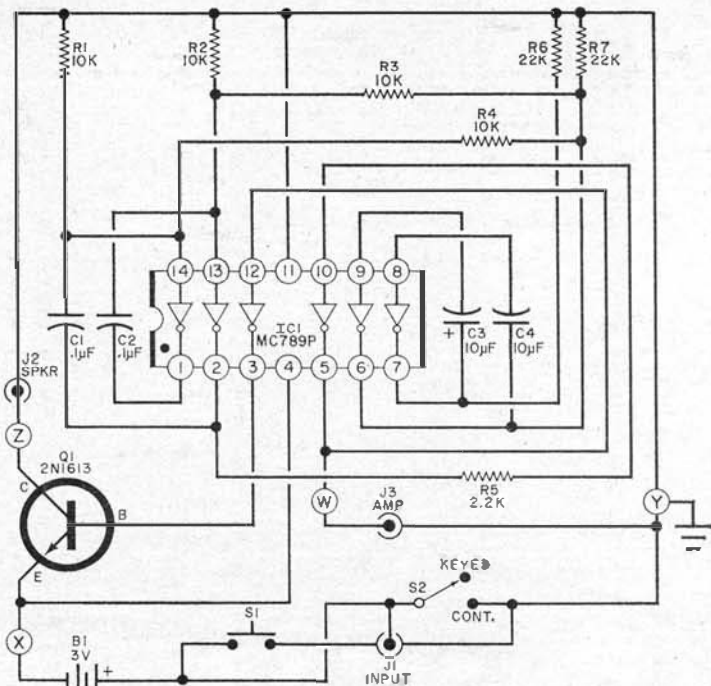

Fig. 1. The circuit is essentially a pair of audio oscillators that interact with each other to produce the strange sound. Note that the positive side of the battery is grounded to the chassis to ease the wiring.

PARTS LIST

B1—D cell (2)
 C1, C2—0.1- μ F, 10-volt disc ceramic capacitor
 C3, C4—10- μ F, 10-volt electrolytic capacitor
 IC1—MRTL hex inverter (Motorola MC789P)
 J1-J3—Phono jack
 Q1—2N1613 npn medium-power transistor (or similar)
 R1-R4—10,000-ohm, $\frac{1}{4}$ -watt resistor
 R5—2200-ohm, $\frac{1}{4}$ -watt resistor
 R6, R7—22,000-ohm, $\frac{1}{4}$ -watt resistor

S1—S.p.s.t. normally open pushbutton switch
 S2—S.p.s.t. slide switch
 Misc.—PC terminals (4), 3" x 4" x 5" case, mounting hardware, battery holder (Keystone 176), PA1 speaker and enclosure (optional), wire, solder, etc.
 Note—The following are available from Southwest Technical Products, Box 16297, San Antonio, Texas, 78216: etched and drilled circuit board, \$1.50; complete kit of all parts including prepunched, vinyl-clad case, but less batteries and speaker, \$6.90, postpaid in U.S.A.

HOW IT WORKS

The integrated circuit used here is called a hex inverter and contains six separate inverting amplifier stages. Two of these stages are combined with R6, R7, C3, and C4 to form a 5-Hz astable multivibrator (square-wave oscillator). Two more inverters are combined with R1 through R4 and C1 and C2 to form a second astable multivibrator that can operate at either 500 or 1000 Hz, depending on the state of the 5-Hz multivibrator and feedback through R3 and R4.

The remaining inverters provide load isolation, while transistor Q1 provides enough drive to handle a permanent-magnet speaker.

Power for the Alarm is obtained from two D cells. Any other medium-current d.c. supply with a voltage from 1.5 to 6 volts can be used. Switches S1 and S2 and jack J1 are all in parallel to energize the Alarm. To simplify the assembly, the case is connected to the keyed positive supply level (PC terminal Y).

from the top. Be sure to orient it properly and use a small soldering iron and fine solder when installing it. Also, be careful about the polarities of electrolytic capacitors C3 and C4.

Assemble the Alarm in a 3" x 4" x 5" metal box. The battery holder is mounted on the bottom with pop rivets or #6 hardware, while the PC board goes on the top with suitable spacers or #6 hardware.

Operation: To test the Alarm, either connect the amplifier output (J3) to a suitable amplification system or attach

Fig. 2. Actual-size foil pattern for the Two-Tone Generator. The IC is oriented so that pin 1 is adjacent to the small dot on the foil pattern. After fabrication, the board can be drilled as shown below, and PC terminals can be used at the four lettered locations. The board is supported by spacers at each corner location. Component location is shown in Fig. 3.

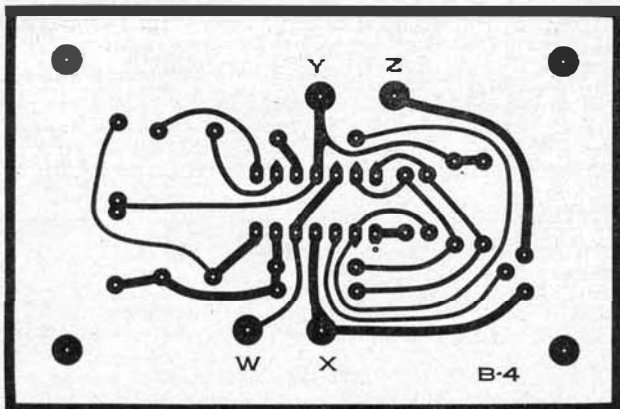
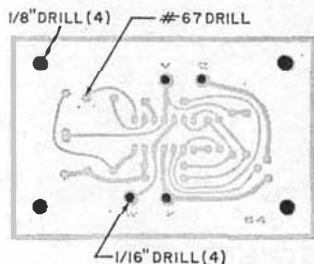

a low-impedance (4-, 8-, or 16-ohm) speaker to the speaker jack (J_2). The Alarm should operate immediately.

To vary the output sound, add a 500- or 1000-ohm potentiometer in series with S_1 .

Capacitors C_1 and C_2 determine the frequency of the lowest note, while C_3 and C_4 determine the switching rate. The difference between the highest and lowest notes is determined by R_3 and R_4 . You can experiment with any of these values to get different audio results.

Volume should be more than enough for most applications. If you want more, however, try using a higher supply voltage (up to 6 volts). You can also use an output matching transformer or a high-efficiency horn-type speaker. \square

COVER FEATURE

This is the first in a series of simplified integrated circuit projects. In addition to the Two-Tone Alarm, the series includes a Signal Injector, a Bounceless Pushbutton, a Shift Register, and a 100-kHz Standard. The last four will appear in future issues of POPULAR ELECTRONICS. In these articles, the author demonstrates a variety of uses of commonly available integrated circuits. The projects themselves may be used for classroom or Science Fair demonstrations, or they may be repackaged and put to more constructive uses. Each project will be complete and will include details on circuit operation.

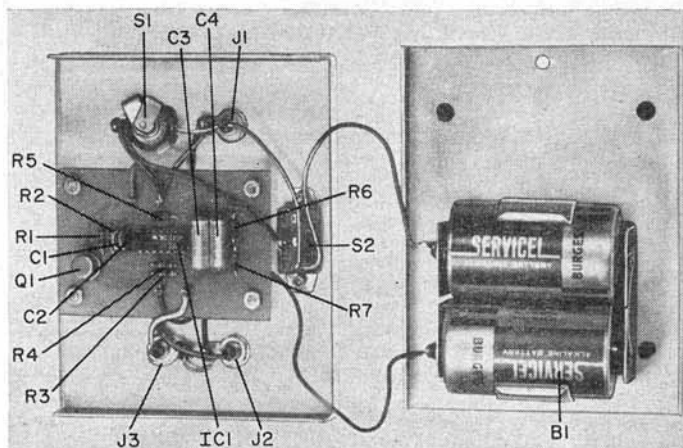

Fig. 3. Although the alarm can be built in almost any type of case, the prototype was built within a small metal enclosure. Install the components on the PC board as shown at left and mount batteries on other side.