



BUILD THE PSYCH-TONE

MELODY SYNTHESIZER WITH 28 CONTROLS & 63-NOTE MEMORY

This is a new and unusual approach to music synthesis. The sounds it produces are modern—to say the very least—and the operation is extraordinarily simple. Technically, this is a “pseudo random sequence generator” operating as a tune computer with tempo, voicing selection, tone shaping, and pause gates.

BEETHOVEN couldn't synthesize music like a Moog, nor could he be programmed to turn out a melody of the listener's own choosing. The “Psych-Tone” doesn't do those things either, but it is a real composer of syn-

thetic music. Set up on its internal digital computer are 1728 different 63-note sequences that can be selected and combined with any of 63 pause combinations to produce 108,864 different melodic lines. These melodies can be played at almost any tempo, pitch, or volume and they can be played forward or backward, right side up (normal scale) or upside down (inverted scale). Six different voices are provided and the user has full control of the attack, sustain, and decay of the output.

Because of the wide flexibility of the controls, the music can have the sound of a violin, a piano, or something like nothing you ever heard before. On occasion, the music may

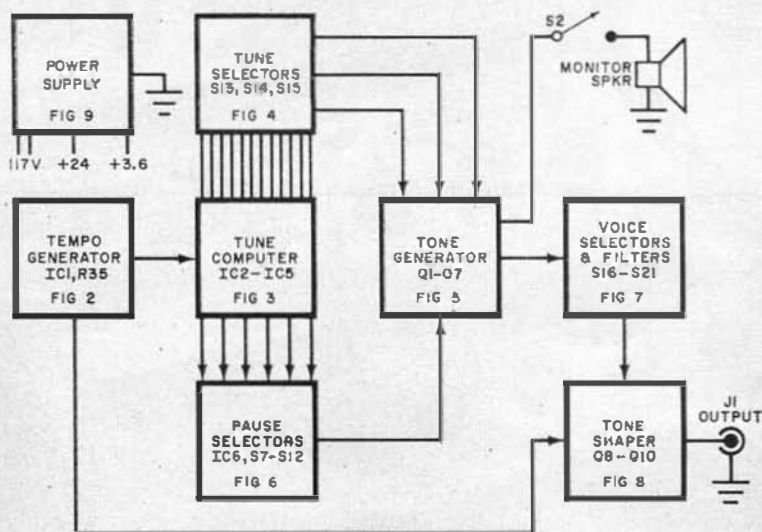

Fig. 1. The overall block diagram shows the signal flow for the system. Note that voicing filters and tone shaper are not linked to the monitor speaker.

PARTS LIST

C1—4000- μ F, 6-volt electrolytic capacitor
 C2—0.1- μ F, 10-volt disc ceramic capacitor
 C3—500- μ F, 50-volt electrolytic capacitor
 C4—100- μ F, 25-volt electrolytic capacitor
 C5, C10—0.047- μ F, 50-volt Mylar capacitor
 C6, C8—0.22- μ F, 50-volt Mylar capacitor
 C7, C15, C16—47- μ F, 6-volt electrolytic capacitor
 C9, C12, C14—0.47- μ F, 50-volt Mylar capacitor
 C11—0.01- μ F disc capacitor
 D1-D3—1-ampere, 100-volt diode (1N4002 or similar)
 D4—24-volt, 1-watt zener diode (1N4749 or similar)
 D5-D7, D9—Silicon diode (1N914 or similar)
 D8—3.3-volt zener diode (1N746 or similar)
 IC1—Dual buffer (MC799P)
 IC2, IC4—Dual flip-flop (MC791P)
 IC5, IC6—Quad two-input gate (MC724P)
 J1—Phono jack
 Q1-Q3, Q7-Q9—Transistor (National 2N5129)
 Q4—Transistor (National 2N5139)
 Q5—Transistor (Motorola 2N4871, do not substitute)
 Q6—Transistor (Motorola MP86523, do not substitute)
 Q10—Transistor (Motorola 2N4351, do not substitute)
 R1—330-ohm, $\frac{1}{2}$ -watt resistor
 R2-R1, R12, R31, R33, R36-R38—1000-ohm, $\frac{1}{4}$ -watt resistor
 R5-R7—22,000-ohm, $\frac{1}{4}$ -watt resistor
 R8, R10—100,000-ohm potentiometer
 R11—11,000-ohm, $\frac{1}{4}$ -watt resistor
 R13, R18—1500-ohm, $\frac{1}{4}$ -watt resistor
 R14—5000-ohm potentiometer

R15—470-ohm, $\frac{1}{4}$ -watt resistor
 R16—20-ohm, $\frac{1}{4}$ -watt resistor
 R17, R20—100,000-ohm, $\frac{1}{4}$ -watt resistor
 R19, R28—4700-ohm, $\frac{1}{4}$ -watt resistor
 R21, R23—27,000-ohm, $\frac{1}{4}$ -watt resistor
 R22, R24, R25—1-megohm potentiometer
 R26, R30—3300-ohm, $\frac{1}{4}$ -watt resistor
 R27—1000-ohm potentiometer
 R29—2200-ohm, $\frac{1}{4}$ -watt resistor
 R30—3300-ohm, $\frac{1}{4}$ -watt resistor
 R34—8200-ohm, $\frac{1}{4}$ -watt resistor
 R35—10,000-ohm potentiometer
 R39, R40—3.3-megohm, $\frac{1}{4}$ -watt resistor
 S1-S12—Dpdt rocker switch
 S13-S15—Single-pole, 12-position, non-short-circuiting rotary switch (Mallory 32112J)
 S16-S21—Interlocked six-station dpdt push-button switch assembly (Southwest Technical SW-9678-sif or similar)
 T1—Power transformer: secondaries: 24 volts at 100 mA, 6.3 volts CT at 400 mA
 Misc.—Printed circuit terminals (47, optional), 3.2-ohm speaker, suitable chassis, sub-chassis, grommets (3), line cord with strain relief, bottom plate with mounting hardware, rubber feet, (4), switch hardware, ground lugs (3), $\frac{1}{4}$ " knobs (9), $\frac{3}{8}$ " knobs (3).
 Note—The following are available from Southwest Technical Products, Box 16297, San Antonio, TX 78216: etched and drilled printed circuit board at \$6.50, postpaid; complete kit with chassis, dialplate, and hardware at \$47.65 plus postage and insurance for 7 lb.

sound familiar but it is more likely to have a science-fiction flavor with many wild tonal sequences.

The Psych-Tone can be used with its internal monitor speaker; but, preferably, it should be connected to an external power amplifier to take advantage of the various voices and the sustain, attack, and decay provisions which are not available when only the monitor speaker is used.

General Circuit Operation. The Psych-Tone consists of seven operational blocks and a power supply as shown in Fig. 1. The tempo generator determines the reference beat (or clock) for the tune computer, which cycles through 63 different states in step with the clock pulse. The three tune selector switches convert the initial 63-note sequence into any one of 1728 different combinations. The tune computer also drives a pause selector circuit that decides when pauses are to be produced instead of tones. The selected sequence of notes and pauses then goes to a tone generator where it is converted into audio tones.

In the voice selector (filters) the tones are shaped into one of six selected voices, in a manner similar to the operation of an electric organ. The tones are further shaped in a variable-gain circuit that provides for adjusting the duration (sustain), attack (how fast

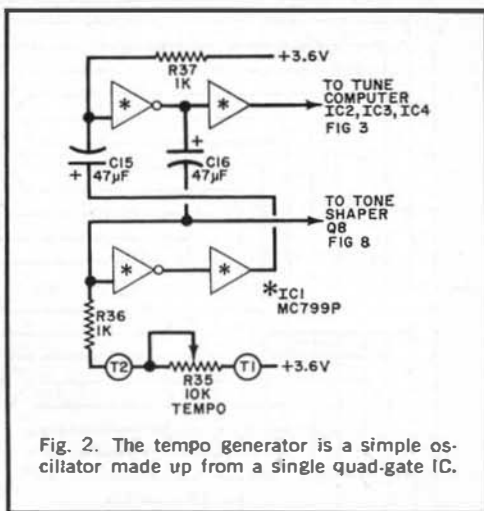

Fig. 2. The tempo generator is a simple oscillator made up from a single quad-gate IC.

the tone reaches full volume), decay (how fast the tone dies away from full volume), and loudness.

Tempo Generator. This circuit, shown in Fig. 2, contains a single integrated circuit (IC1) operating as an astable multivibrator. Two square wave outputs are produced—one having a fast fall time and high drive capability for the tune computer, and the other for

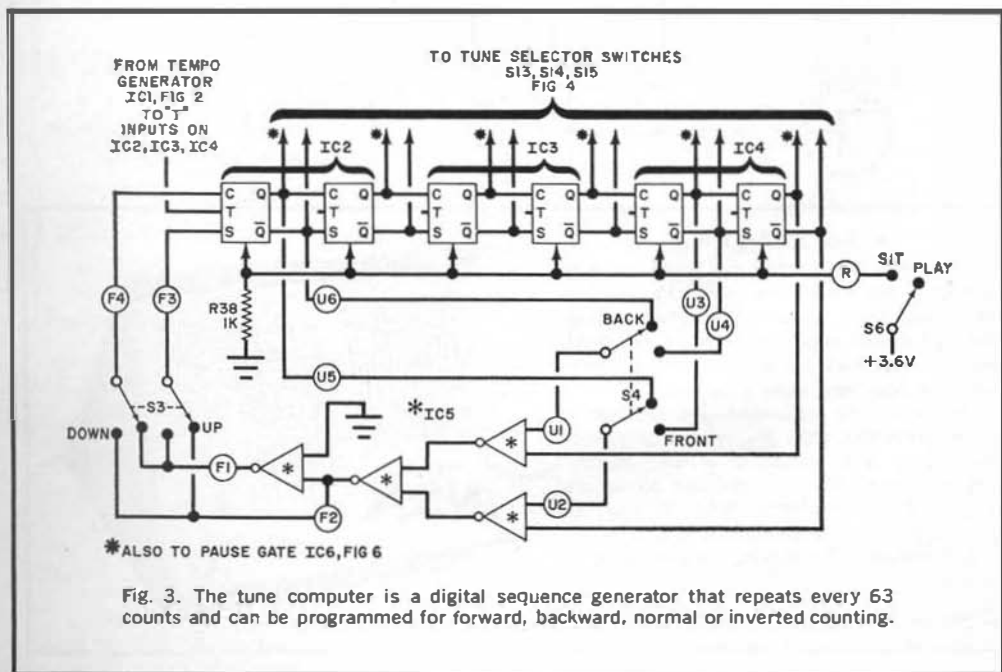

Fig. 3. The tune computer is a digital sequence generator that repeats every 63 counts and can be programmed for forward, backward, normal or inverted counting.

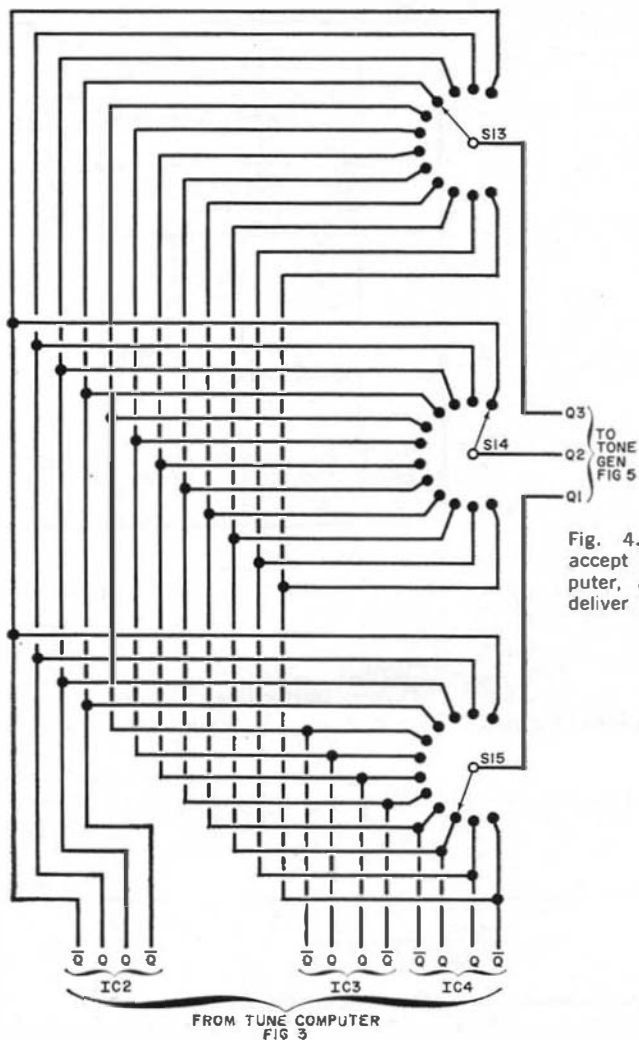
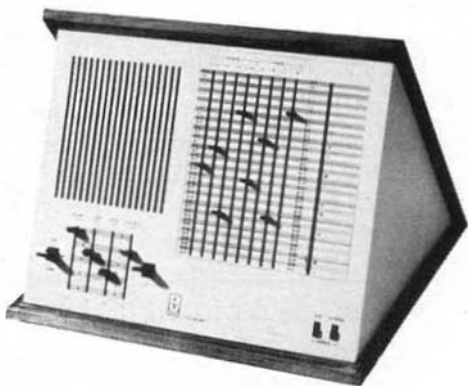

Fig. 4. Three tune-selector switches accept 12 outputs from the tune computer, and after the desired selection, deliver three signals to tone generator.

ALSO AVAILABLE

A recently introduced unit which is quite similar to the Psych-Tone is the Muse, made by Triadex, Inc., Newton Upper Falls, Mass. With 14 trillion note combinations, the Muse has four switches for volume, tempo, pitch, and fine pitch and eight slide switches. Four of the latter vary the interval and thus determine the notes, while the other four control the theme and variations of the melody. Triadex warns that it is possible to set up a composition that would take 30 years to play—which may be a little too long if you're only interested in the finale. The Muse is listed at \$300.

Circle No. 92 on Reader Service Page 15 or 95



the tone shaper sustain circuit. The tempo (beat) is adjusted over a 5:1 range by potentiometer *R35*. If desired, the values of *C15* and *C16* can be increased or decreased to slow down or speed up the tempo, respectively.

Tune Computer. As shown in Fig. 3, the computer is a "pseudo random sequence generator." Like a random noise source, the computer sequences appear to be totally unrelated. However, this circuit can be programmed to return to exactly the same random sequence at any time. The logic consists of a six-stage shift register (*IC2*, *IC3*, and *IC4*) and an EXCLUSIVE OR gate (*IC5*). The shift register is toggled by the tempo generator described above.

At each toggle pulse, each stage of the register shifts a 1 or a 0 to the next stage. The last two stages (*IC4*) drive the EXCLU-

SIVE OR gate. Switches *S3* and *S4* connect the logic so that the shift register goes forward, backward, with a normal scale, or with an inverted scale. The computer repeats every 63 counts. While any short sequence appears to be a random train of binary words, the same sequence repeats every time. Selector switch *S6* holds the computer in any interrupted state until the user is ready to re-start the sequence.

Each of the six stages has two possible outputs: a true or Q and the complement or not Q output. Thus there are twelve outputs which are selected by *S13*, *S14*, and *S15*, shown in Fig. 4 so that three signals are supplied to the tone generator.

Tone Generator. The circuit shown in Fig. 5 is basically a unijunction transistor oscillator (*Q5*) whose frequency is determined

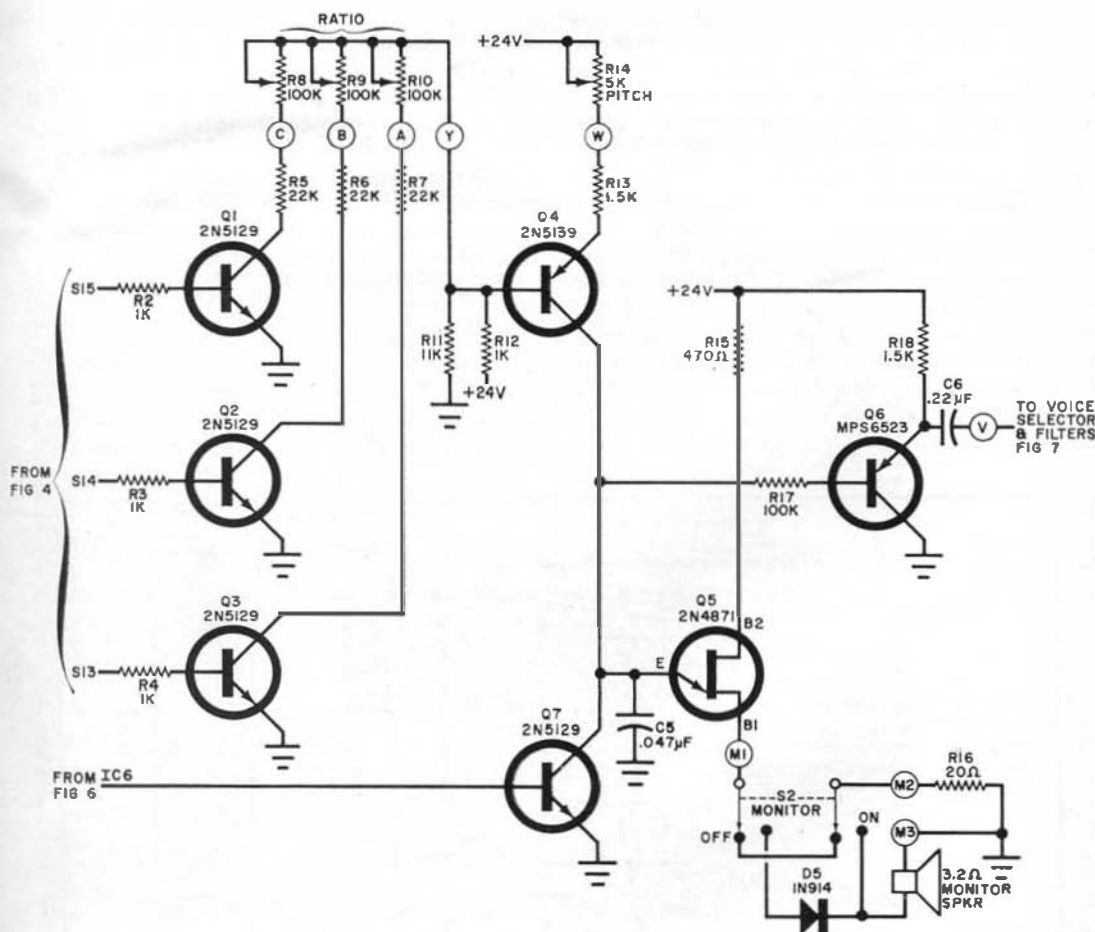

Fig. 5. The tone generator consists of a UJT oscillator whose frequency is dependent on the current flowing through *Q4*. This in turn is determined by the pitch control and operation of *Q1* through *Q3*.

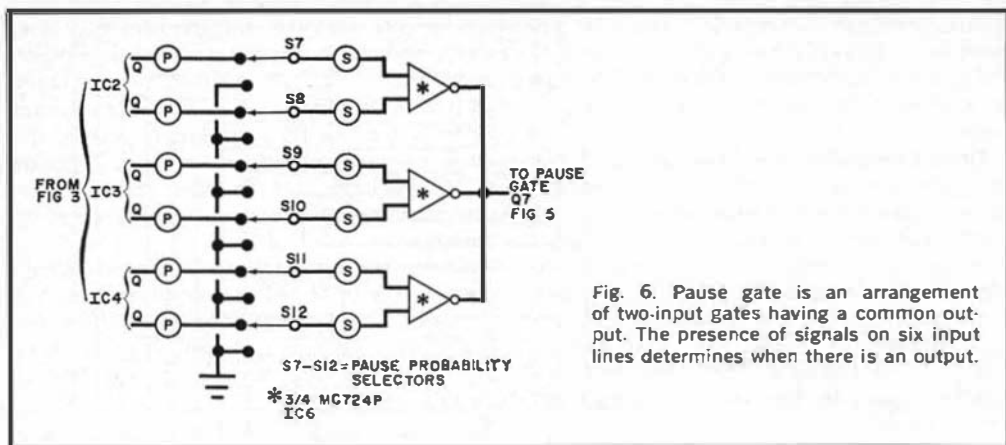

Fig. 6. Pause gate is an arrangement of two-input gates having a common output. The presence of signals on six input lines determines when there is an output.

by the value of $C5$ and the collector current of $Q1$.

Transistors $Q1$ through $Q3$ cause the base voltage of $Q1$ to vary in accordance with the signals selected by $S13$, $S14$, and $S15$. The effect of the signals on $Q1$ is determined by the collector loads on $Q1$ through $Q3$. These are potentiometers $R8$ through $R10$. Normally, one control is set near maximum, one at the midpoint and the other near minimum to get a weighted average and provide a wide spread of tonal values. The three ratio potentiometers permit an infinite variety of tonal forms for each of the basic sequences.

Pitch is controlled by $R14$, which, when combined with the tone-shifting base voltage applied to $Q1$, determines the frequency of oscillation. Resistor $R17$ and transistor $Q6$ form a buffer amplifier having a low-imped-

ance output for the voice selector without loading the UJT oscillator.

Pauses are provided by $Q7$, which shorts out $C5$ and prevents a tone from being generated when a pause is desired.

The monitor speaker is switched in and out by $S2$ while diode $D5$ insures the same pitch whether the speaker is used or not. The speaker responds only to tone and pause sequences and is not affected by the sustain, attack, decay, and volume controls. However, the volume on the monitor is sufficient for practice sessions.

Pause Gate. As shown in Fig. 6, the pause gate consists of three two-input gates ($IC6$) arranged so that a logic 1 on any input allows the tones to be produced (through $Q7$). The six inputs come through selector switches $S7$

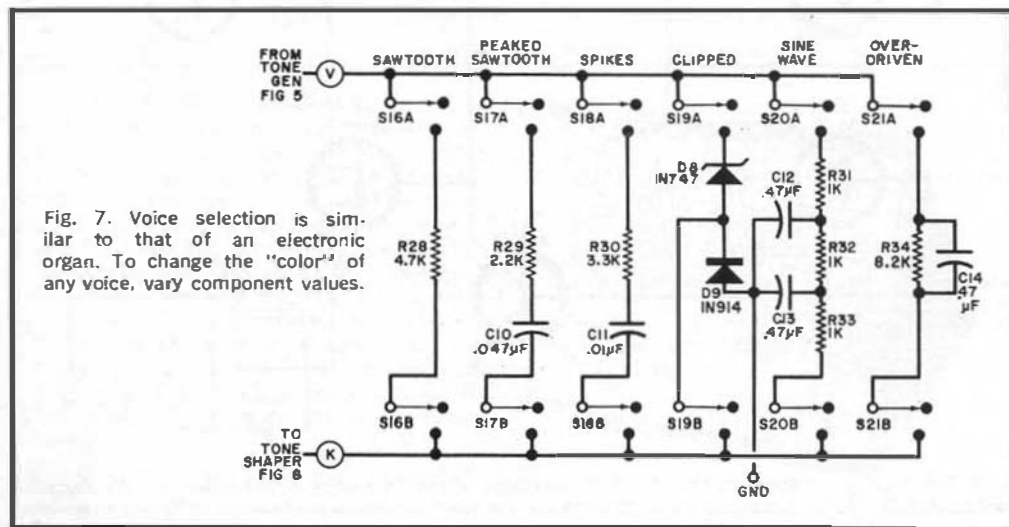
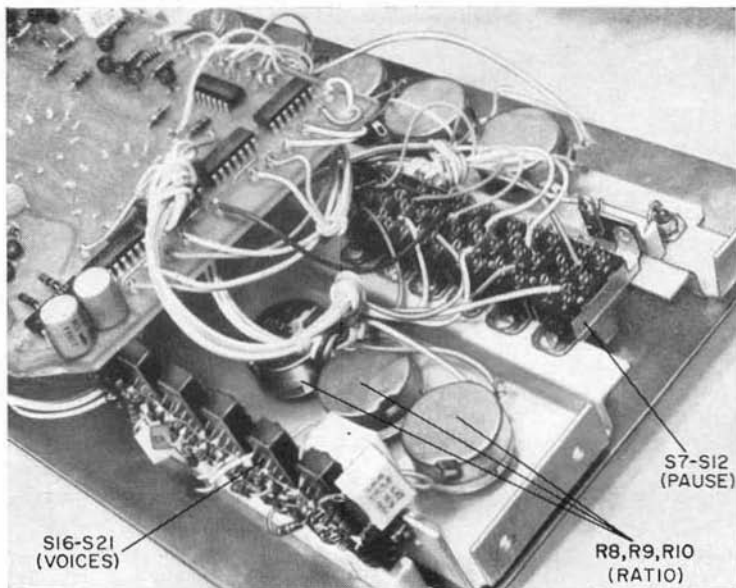
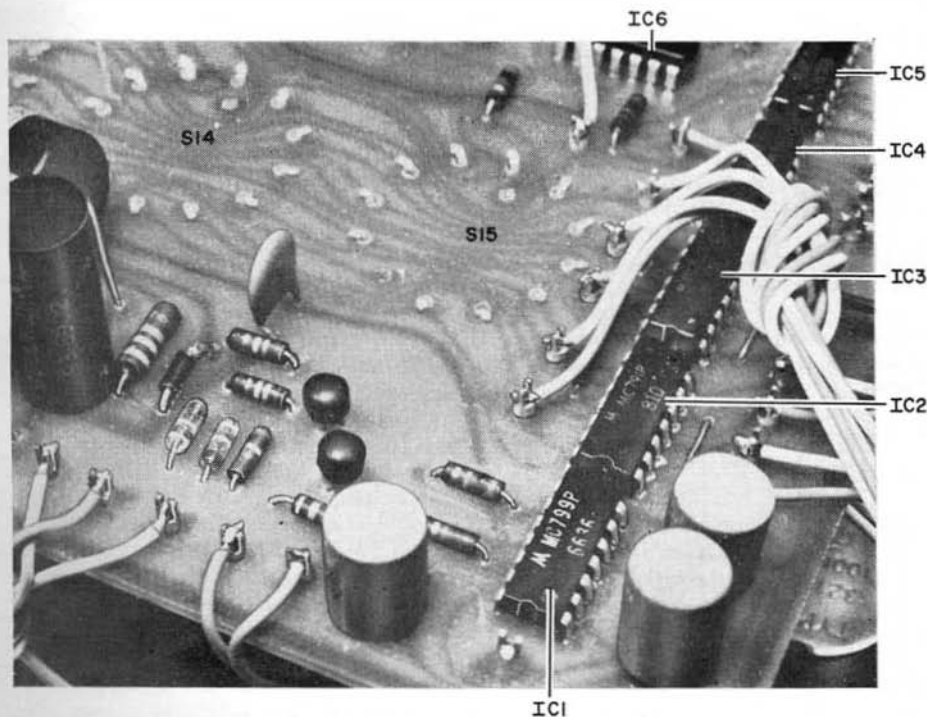

Fig. 7. Voice selection is similar to that of an electronic organ. To change the "color" of any voice, vary component values.



Although any mechanical arrangement can be used, the prototype was assembled to the front panel with a set of brackets and the potentiometer mounting hardware. The PC board is supported by the three tune-selector switches.



The tune-selector switch terminals fit through holes drilled in the PC board, and are soldered to the foil side of board. The three switches then support the board away from the panel.

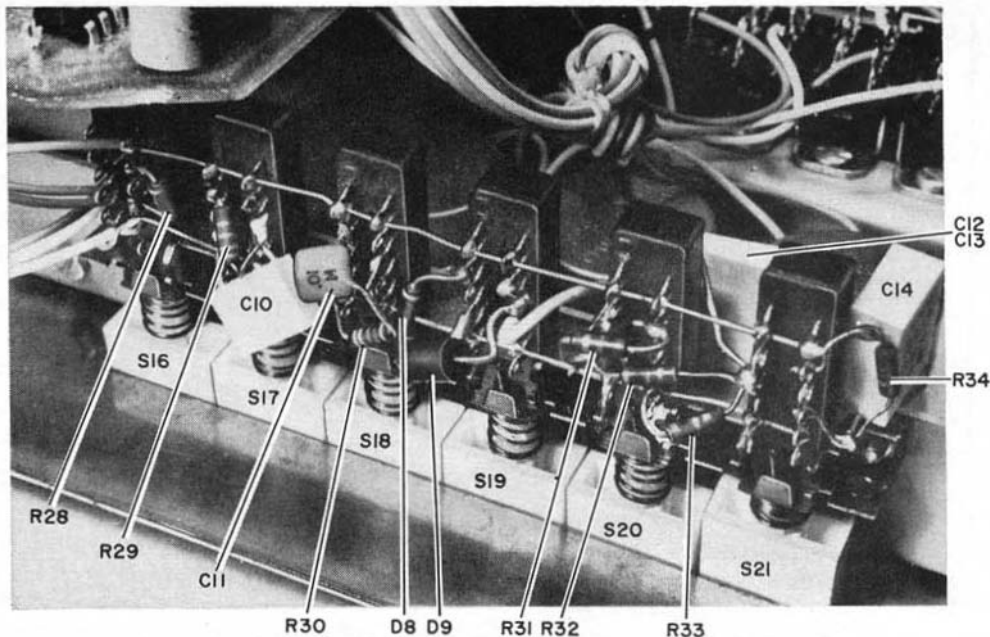

The six voice switches are mounted on their own bracket with other components attached directly. The switch combination should be such that only one switch can be operational at any time.

through *S12*, which provide either a Q or not Q signal, the latter being ground. If all the switches were grounded, there would be no tone generated since the common output would be high, saturating *Q7* and stopping the oscillation of the UJT circuit. If any five switches are grounded, the circuit plays about half the tones, with blanks or pauses at random intervals. With four switches grounded, $\frac{3}{4}$ of the tones are sounded; while grounding any three switches drops one note in eight (on the average). The combination of switches used determines the positions of the pauses. Thus, there are 15 different ways to eliminate every fourth note on the average and 20 different ways to play the computer with an average of one note in eight missed.

Voice Selector. The circuit shown in Fig. 7 is controlled by a six-station interlocked pushbutton assembly (*S16* through *S21*). The switches determine the waveform of the tone produced: sawtooth, peaked sawtooth, spiked, clipped, rough sinusoid, or overdriven. The filters suggested here were chosen for economical purposes; filters such as those found in electronic organs may be used to obtain other tonal qualities.

Tone Shaper. The tone shaper (see Fig. 8) converts the filtered tones into individual notes. Transistor *Q10* is biased by *R39* and *R40* to act as a variable resistor which conducts both positive and negative portions of a waveform equally. This transistor acts as a shunt to ground from the output terminal.

The voltage across *C8* determines the operational mode of *Q10*. If this voltage is 6 or more volts positive (with respect to ground), *Q10* acts as a low resistance and shorts out the signal. If *C8* is grounded, *Q10* passes all the signal. Intermediate values of the control voltage result in a controlled output level.

The rate at which *C8* goes from a positive voltage to ground determines how fast the output amplitude rises (the attack time); the length of time that *C8* stays near ground determines the sustain; and the rate of discharge on *C8* determines the decay time. The final output varies greatly for various values of attack, sustain, and decay. With a moderate amount of all three, a violin effect is obtained. With sharp attack, short sustain, and long decay, the percussive sound of a piano or chime is generated. A long attack, long sustain, and very short decay provide a totally unreal sound similar to a recording being

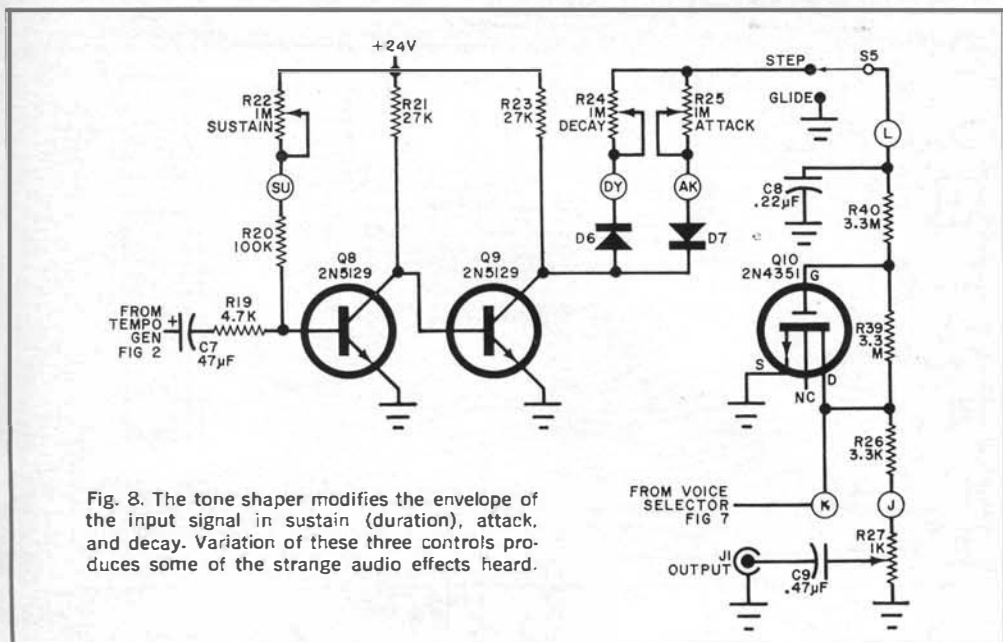

Fig. 8. The tone shaper modifies the envelope of the input signal in sustain (duration), attack, and decay. Variation of these three controls produces some of the strange audio effects heard.

played backward. Tremolo effects are obtained when the decay is set to overlap into the next tone, producing a "waa-waa". With *S5* in the glide position, *Q10* is disabled and the sound is similar to that of a bagpipe.

Transistor *Q8* is a monostable stage providing the sustain effect. Its output is controlled by *R22* and is inverted by *Q9*. The output of *Q9* is routed to *C8* for the attack effect or *R24* for decay.

Power Supply. The circuit of the power supply is shown in Fig. 9. It generates 24 volts dc for the tone generator circuit and 3.6 volts dc for the digital logic circuits.

Construction. An etched and drilled PC board is available commercially (see Parts List of Fig. 1) or you can make your own from a foil pattern that can be obtained by sending 25¢ to Editorial Department, POPULAR ELECTRONICS, 1 Park Ave., New York, NY 10016.

Install the components on the board as shown in Fig. 10. Install the five jumpers next to the IC's using insulated sleeving on the two jumpers toward the center of the board. You may use PC terminals for the external connections to the board.

To save a lot of individual wiring, switches *S13* through *S15* are mounted directly on the

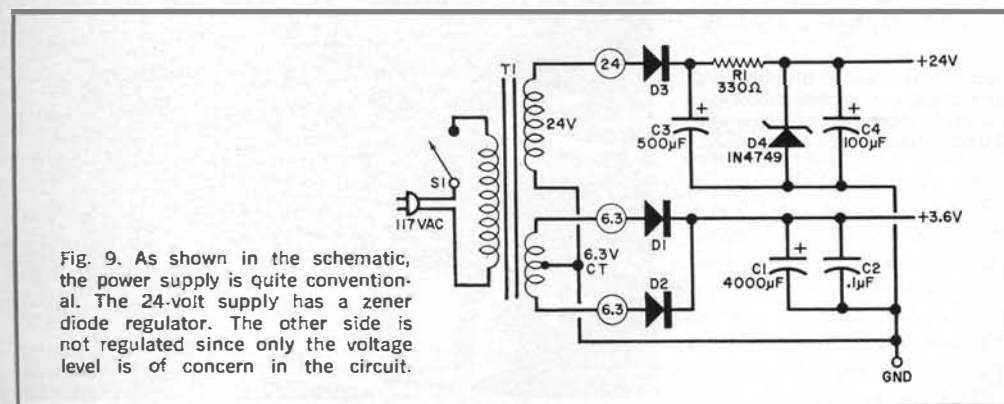

Fig. 9. As shown in the schematic, the power supply is quite conventional. The 24-volt supply has a zener diode regulator. The other side is not regulated since only the voltage level is of concern in the circuit.

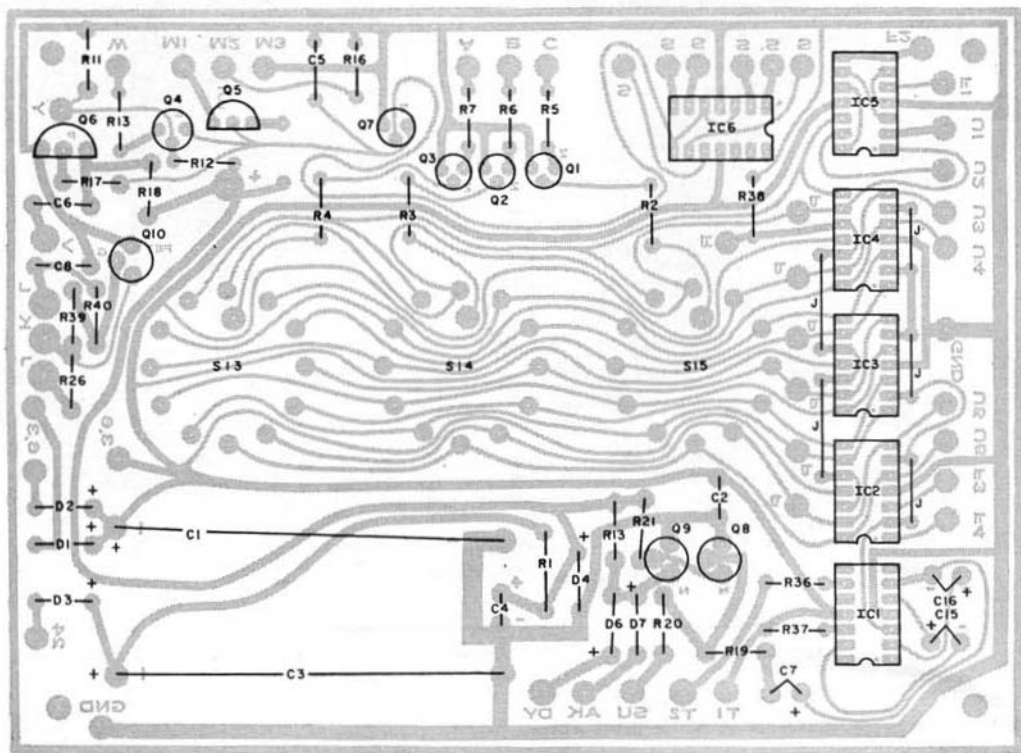

Fig. 10. Component installation. Unfortunately, the actual size foil pattern is too large for the page.

foil side of the board, with the switch terminals inserted through the board. The inserted terminals may be crimped and fastened to the component side of the board with epoxy cement; then solder them to the pads on the foil side. A small wire jumper at the common

terminal of each switch simplifies the final assembly.

When installing the components, use a low-wattage soldering iron and fine solder, and observe the polarities of all components. Several different basing schemes are used on the

Author used a set of brackets and subchassis to assemble prototype. With some ingenuity, any other mechanical arrangement can be used.

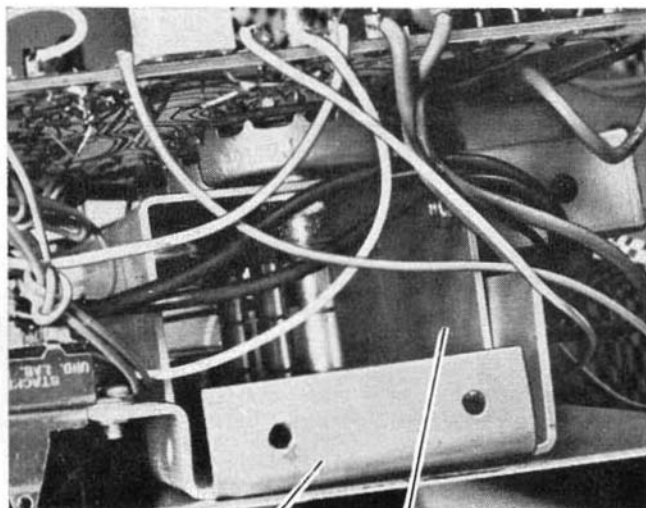

SUBCHASSIS A "U" BRACKET

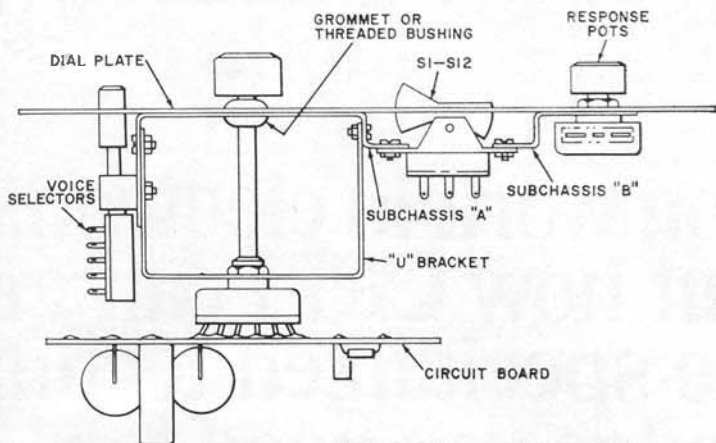

Fig. 11. If you want to use metal supports, this drawing will give you a good idea of how they are used and placed.

transistors so be sure you get them installed properly.

Transistor *Q10* can be damaged by careless handling. To install this component, wait until all the other parts have been mounted on the board. Do not remove the shorting ring that comes with the transistor until you are ready to install it. Just before installation, wrap several turns of bare wire around the

leads at the case, remove the shorting ring, and turn the substrate lead up (it is left unconnected). Install the transistor using a low-power soldering iron (not a gun). Once it is in place, remove the shorting wire.

Two subchassis brackets and a larger U-shaped bracket are used in the final assembly (see Fig. 11). The dialplate is secured to the brackets using the potentiometer hardware. The transformer is mounted wherever convenient. The bottom panel supports the speaker.

To avoid wiring confusion, it is best to use several colors of wire and group them into harnesses by tying them or slipping them through lengths of sleeving.

Preliminary Checkout. Double check all wiring, install the various knobs, identify the detents on the switches, and use some form of lettering to mark all controls and switch positions.

Plug the unit in, turn on switch *S1* and measure both supply voltages to make sure they are correct. Place the monitor switch (*S2*) in the ON position and set *S6* to PLAY. Set any three pause select switches (*S7* through *S12*) up and the other three down. The Psych-Tone should start to compose. Connect an external audio amplifier and speaker to *J1* and note the effects of the voice selectors (*S16* through *S21*) and all other controls.

There are no operating rules. Any and all of the 28 operating controls can be used in any sequence to produce any desired effect.

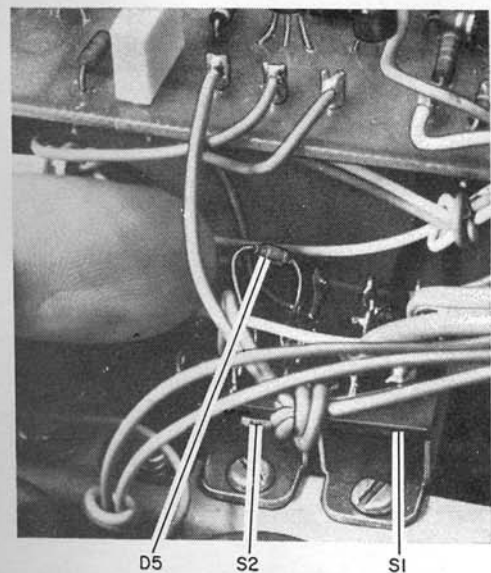

In most cases, components directly associated with a switch are mounted on the switch terminals.