

INTEGRATED CIRCUITS
SIMPLIFY CONSTRUCTION
OF REAL ELECTRONIC DICE
FOR FUN,
PLEASURE, OR PROFIT.
AND PUT . . .

TECHNICALLY SPEAKING, this is a Mod 6 walking ring counter using six J-K flip-flops and lamp drivers. Decoding is reduced to four circuits and the readout is via a selective arrangement of 14 low-voltage bulbs. From a practical aspect, this is an electronic pair of dice that can't be loaded.

SPOTS BEFORE YOUR EYES

By **DON LANCASTER**

While intended primarily for use as a parlor-type family game, this gadget will also make a dandy science fair project for illustrating the basic principles of probability and computer counter circuitry, and will serve as an immediate attention-getting device at any exhibit or display. It measures 6¼" x 3¾" x 2", and should cost from \$18 to \$30, depending on how fancy you care to make your particular version. Complete kits and/or all special parts are readily available.

COVER STORY

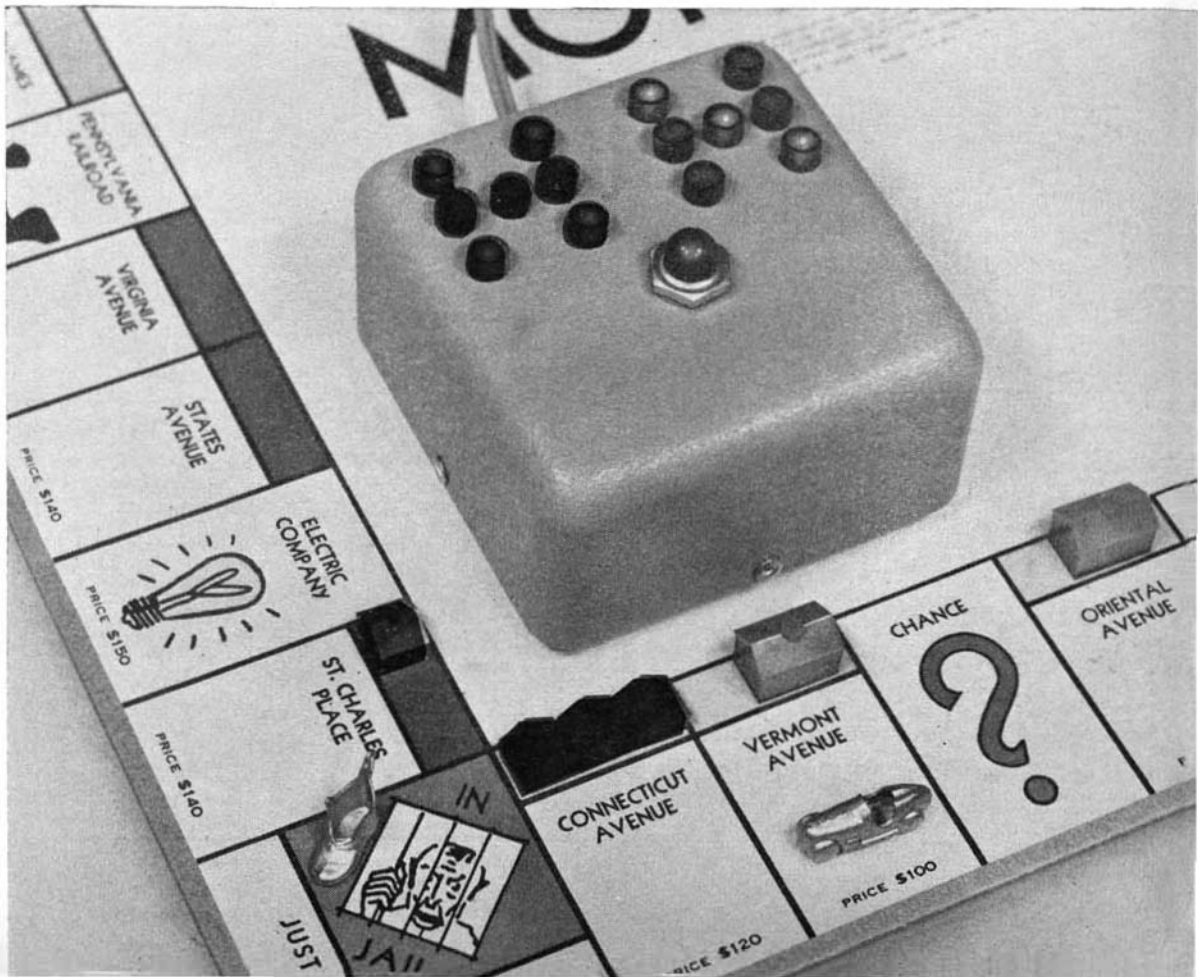

Q1-Q10 (EACH) MPS6554
 I1-I14 (EACH) 6V-50 mA BULB
 D2-D4 (EACH) 1N4001

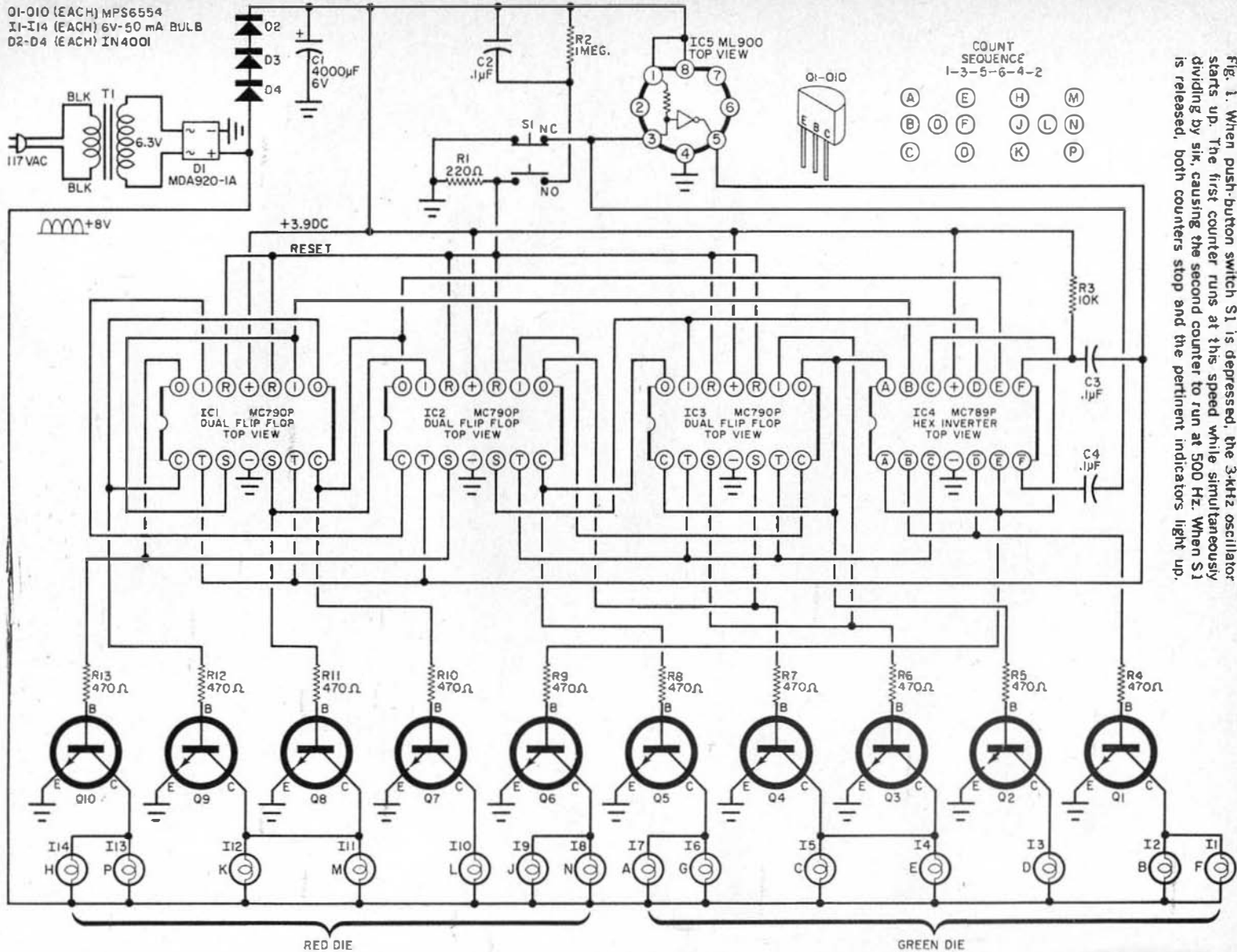
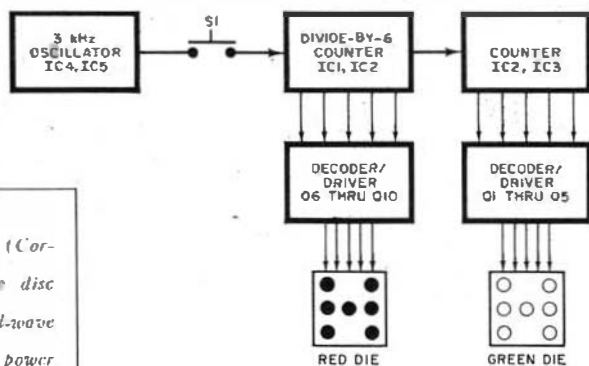

Fig. 1. When push-button switch S1 is depressed, the 3-KHz oscillator starts up. The first counter runs at this speed while simultaneously dividing by six, causing the second counter to run at 500 Hz. When S1 is released, both counters stop and the pertinent indicators light up.

Fig. 2. Since each die is fed from a separate counter, and there is no fixed time during which the counters cycle through their stages, the final lamp indication is random, as with real dice.



PARTS LIST

- C1—4000- μ F, 6-volt electrolytic capacitor (Cornell Dubilier BR 4000-6, or similar)
 C2, C3, C4—0.1- μ F, 10-volt miniature disc ceramic capacitor
 D1—MDA920-1A 1-ampere, 50-volt, full-wave bridge rectifier assembly (Motorola)
 D2, D3, D4—1N4001 or similar silicon power diode
 I1-I4—6.3-volt, 50-mA, pilot lamp assembly, 7 red, 7 green (Southwest Technical Products Corp. L-92, or similar)*
 IC1, IC2, IC3—MC790P dual J-K flip-flop (Motorola)
 IC4—MC789P hex inverter (Motorola)
 IC5—uL900 buffer (Fairchild)
 Q1-Q10—MPS6554 transistor (Motorola)
 R1—220-ohm, $\frac{1}{4}$ -watt carbon resistor
 R2—1-megohm, $\frac{1}{4}$ -watt carbon resistor
 R3—10,000-ohm, $\frac{1}{4}$ -watt carbon resistor
 R4-R14—470-ohm, $\frac{1}{4}$ -watt carbon resistor
 S1—Two-circuit "make one, break one" push button, snap-action
 T1—6.3-volt, 0.6-ampere miniature filament transformer (Knight 54D1416, or similar)
 1—6 $\frac{1}{2}$ " x 3 $\frac{3}{4}$ " x 2" case and cover (Morry Davis #240, or similar)
 1—3 $\frac{3}{8}$ " x 2 $\frac{1}{2}$ " x 1/16" printed circuit board*
 Misc.—Line cord and strain relief, wire nuts (2), PC terminals (17), #6 x $\frac{3}{8}$ " threaded standoffs (4), #6 x $\frac{1}{4}$ " screws (4), insulated wire jumpers (15), wire, solder, etc.

*The following are available from Southwest Technical Products Corp., 219 W. Rhapsody, San Antonio, Tex. 78216: etched and drilled circuit board, \$3.50; kit of 14 pilot lamp assemblies including 1 spare bulb, \$4.00; complete kit of all parts including fully punched and finished plastic case, \$30.00; postpaid in USA.

NOTE: Although a metal mounting box is shown both on the cover and in the photo on page 29, the construction details given in this article are for the plastic box called for above.

How It Works. Each of the two dies consists of seven pilot lamps that are lit or not lit dependent upon the commands of an electronic counter and decoder circuit. Figure 1 shows the circuit, while the block diagram in Fig. 2 illustrates basic operation.

There are two electronic counters, each of which has six possible states, just like the six sides of a die. Whenever the control push button (S1) is depressed, a 3-kHz oscillator is connected in the circuit, and both counters rapidly run through all of their states, the first at a 3-kHz rate; because of the divide-by-six

characteristic inherent in the first counter, the second operates at a 500-Hz rate. Since the push button will be held down a good fraction of a second, each counter runs through all of its states many hundreds of times.

When the push button is released, the counters stop in some random state—truly random, as the operator has no control whatsoever over which number is up on either counter when he releases the button. Since each die cycles at different rates and since the dwell time on anyone "side" is identical, true dice odds result.

The six counter states are decoded to produce the familiar die combinations, with the center lamp lit only for a "one," the outside six for a "boxcar," etc. Although seven lamps are used, only those combinations of lit bulbs corresponding to the die patterns are permitted to light.

Each counter requires only four decoding circuits. The first decides "even," or "odd." If the count is "odd," the center bulb lights. The next decoder decides "not one" which lights two diagonally opposite bulbs *except* during a "one." A third decoder decides "four," "five," or "six" and lights the remaining two diagonally opposite bulbs on these counts. The final decoder selects "six" and lights the two remaining bulbs on this count. A bit of reflection will show that these four decodings automatically light the proper number of bulbs in the proper pattern for each die position.

A dual power supply and a special pulse circuit complete the unit. The latter feature resets the counter the instant the push button is depressed, guaranteeing that both counters always start off properly.

Fig. 3. Actual-size layout of printed board. Be careful if you make your own as wiring errors will be hard to find. A commercial board is available (see Parts List).

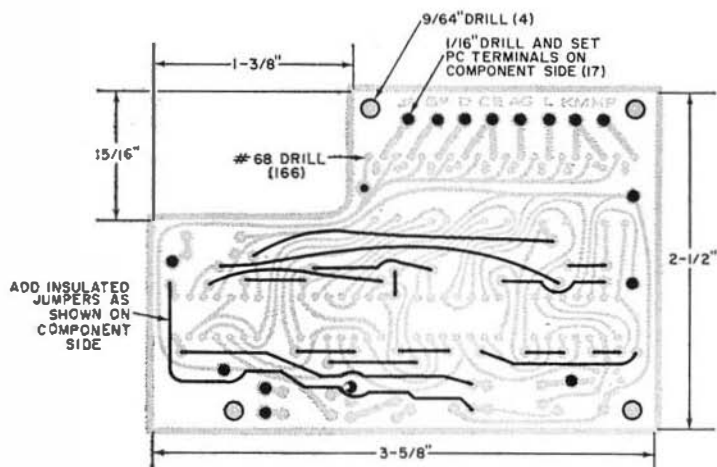
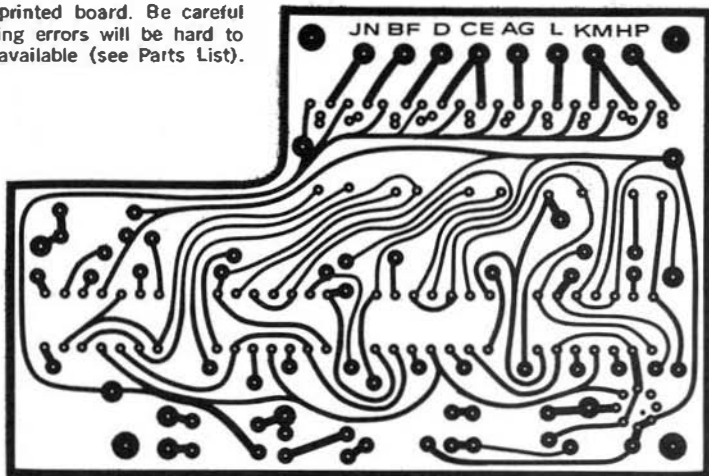

Fig. 4. Before installing components on the board, insert the 16 insulated jumpers as shown here. Observe caution when installing jumpers as errors can be troublesome.

Circuit Details. Integrated circuit *IC5* and part of *IC4* form a 3-kHz multi-vibrator that runs only when *SI*, a 2-circuit, snap-action push button, is depressed. This 3-kHz signal is routed to the two counters consisting of *IC1*, *IC2*, and *IC3*. Incidentally, the total cost of all the integrated circuits is slightly under \$8.00.

High-gain transistors (*Q1* through *Q10*) are used to amplify the low-level logic signals and light one or two bulbs each. Resistors *R4* through *R13* limit the base currents and prevent the bulbs and transistors from excessively loading the counters.

Fig. 5. Component layout and wiring interconnections. Note that *IC1*-*IC4* are identified by notches at one end while *IC5* has one flat side. Lettered bulbs are arranged as per Fig. 1.

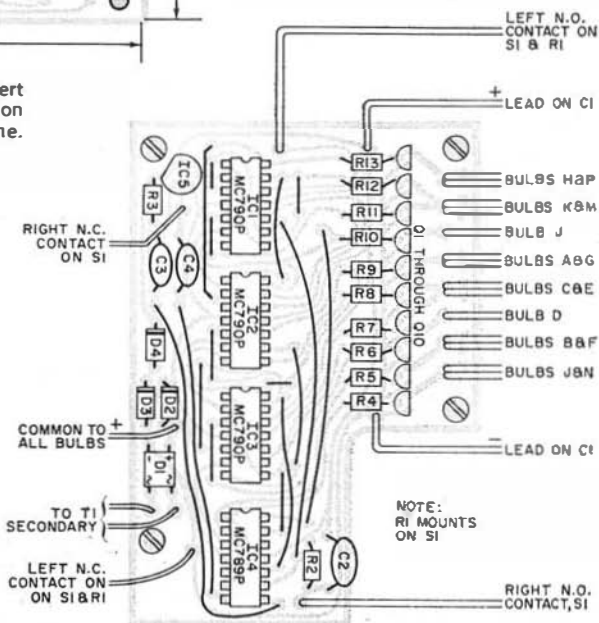

Fig. 6 (right). Finished layout with parts called out in Parts List. Other arrangements can be used if desired.

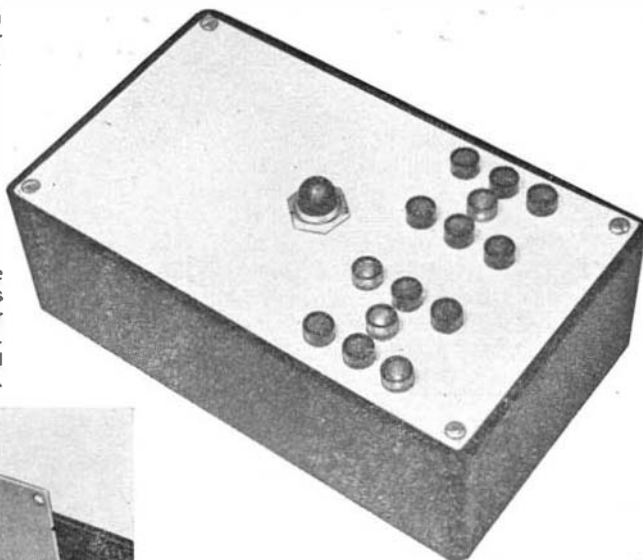
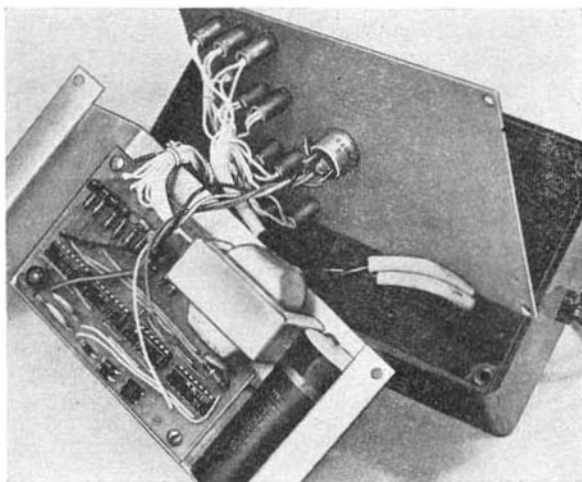

Fig. 7 (below). Internal view of the finished device. Note that R1 is mounted on S1 on the front cover plate along with indicator lamps. Construction details of the U-shaped frame, and the cover, are on page 34.



The bulbs consist of 6-volt, 50-mA units, available as complete, matched red or green panel lamp assemblies from the source listed. Use of higher-current bulbs is not recommended due to the requirement of a larger power transformer and the necessity of using power transistors with exceptionally high gain to obtain any reasonable brilliance and uniformity. Even the transistors selected for the 50-mA bulbs must have a *beta* well over 100, specified at a 100-mA current level. Bear this in mind if you make any substitutions. The particular bulbs and power levels selected are more than bright enough for use under normal viewing conditions, and the actual bulb current is purposely held low to gain a long bulb life.

The dual power supply consists of *T1* and diodes *D1* through *D4*. The bulbs and transistors run off the unfiltered, full-wave rectified low-voltage from *D1*. Di-

odes *D2*, *D3*, and *D4* form a dynamic regulator that drops this voltage and feeds it to filter capacitor *C1* and then to the oscillator and counter circuits. The normal level across *C1* is 3.9 volts; this will vary a tenth of a volt or so with the different die combinations. The value of *C1* selected is the smallest one that will allow the circuit to operate properly—do not substitute for *C1* unless you *increase* its value.

Switch *S1* is a “make one, break one” push button. A d.p.d.t. snap-action type can be substituted simply by not using the extra contacts. Network *R1*, *R2*, and *C2* generates a brief reset pulse each time the push button is initially depressed.

Construction. A printed circuit board is an absolute must for this circuit, owing to the large number of connections and the mounting techniques required for the integrated circuits. You can buy the board already etched and drilled commercially (see Parts List). If you prefer, you can lay out, etch, and drill your own, by following the details in Fig. 3. Be exceptionally careful with your layout if you make your own, for a wiring error in the counter portion of the circuit is quite difficult to find.

Sixteen wire jumpers are required for the PC board. These are formed of insulated wire and mounted on the *compo-*

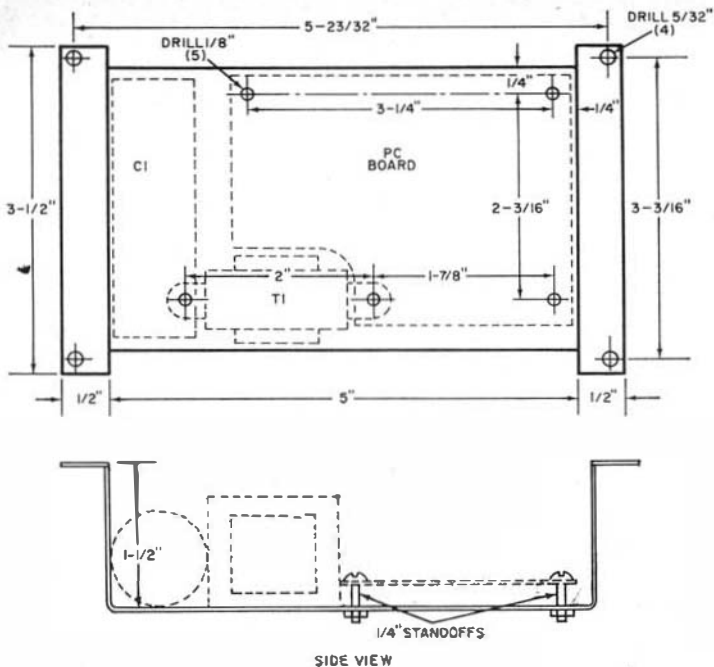

Mechanical details of the U-shaped frame. This frame supports the PC board, capacitor C1, and transformer T1. Note that the PC board uses 1/4-inch standoffs. The frame is designed to fit the plastic box specified.

Fig. 8. Drilling details of the front cover. The lamp holes are drilled so that the lamps can be press-fitted.

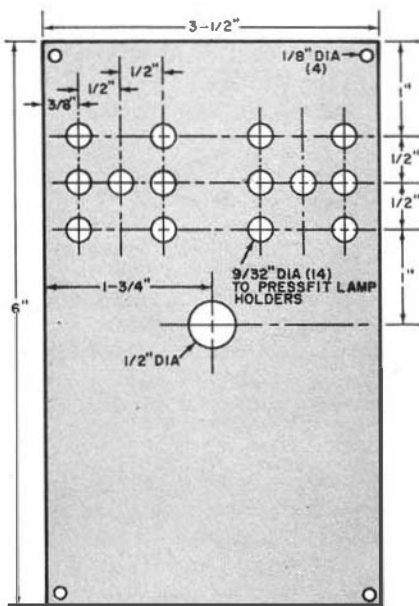

ment side of the circuit board, before any other parts are inserted. Just follow the layout guide in Fig. 4. Be sure to connect the jumpers *exactly* as indicated.

All the circuit parts except T1, C1, R1, S1, and the bulb mount on the board. Use a very small iron and fine solder. Double-check all connections with a magnifying glass and remove all excess solder flux.

Component layout and wiring interconnections are shown in Fig. 5. Note that the integrated circuits may only be connected in one manner, and that they are identified by a notch on one end of the flat packs, and a flat beside lead #8 on IC5. (All IC's are shown *top view* in the schematic.) Each bulb has its die position identified by the code letters shown in the schematic. Use two contrasting colors of pilot lamp assemblies, one for each die.

The electronic dice may be built in virtually any small enclosure. You can use a deep-drawn aluminum box, a conventional chassis, or a plastic instrument case. Mounting details are shown in the photos (Figs. 6 and 7). The U-shaped frame supports the circuit board, transformer, and filter capacitor. The PC board should be spaced slightly above the bottom of

the metal support to avoid any short circuits. The entire assembly can then be mounted in its case.

Details of the lamp assembly drilling on the case cover are shown in Fig. 8. The cover supports the 14 lamp assemblies grouped according to the color and die patterns as well as S1 and R1 (mounted on S1).